



# High Speed Label Applicator

Model : TSLA3600E

The LA3600E is a multi-purpose promotional label applicator for use as either a stand-alone unit or for integration into the DIGI range of dynamic weigh-price labellers and checkweighers.

The LA3600E benefits from a selection of pack guides, Air Concave Shoe or Touch applicators meeting most automatic labelling needs.

## FEATURES

- fast and accurate application of pre-printed promotional labels
- 304 stainless steel and anodised aluminium construction to meet food grade standards
- easy set up and operation, label adjustment via potentiometer
- fully self-contained electronics with product sensing by photocell
- choice of label applicators to suit label requirements
- able to be supplied without powered conveyor for integration into current production lines
- gap sensor options and modified shoe applicators are available where the application of long or transparent labels are required



Shown with Powered  
1 Metre Conveyor

Refer page 2 for specifications

Specifications may change without notice

## LABELLING EQUIPMENT

LABELS | LABELLING EQUIPMENT | PACKAGING EQUIPMENT  
ESL & DIGITAL SIGNAGE | WEIGHING SCALES | POS SYSTEMS  
FOOD EQUIPMENT | MAINTENANCE & REPAIRS | HIRE

1300 970 111  
enquiries@wedderburn.com.au  
www.wedderburn.com.au

# High Speed Label Applicator

Model : TSLA3600E

## SPECIFICATIONS

Package Size	Length: 80 - 500 mm Width: 40 - 250 mm Height: 180 mm Maximum
Label Size - Minimum	Touch Applicators: 36 mm wide x 40 mm high Concave Shoe Air Applicator: 20 mm wide x 20 mm high
Label Size - Maximum	120 mm wide x 120 mm high (150 mm high possible with modification dependent on applicator type)
Label Roll	300 mm outside diameter, 76 mm core, inside or outside wound
Label Application	by 9 finger touch applicator or Concave Shoe Air applicator
Operating Speed	100 packs/min - speed is dependent on both pack and label size
Power Requirements	240V AC 50 Hz single phase
Air Requirements	Minimum 4 bar at 50 to 300 litres/min external clean, dry air
IP Protection	Labeller: to IP20 standard Conveyor: to IP53 standard
Operating Temp.	0 to +40 degrees celsius
Operating Humidity	15 to 85% RH

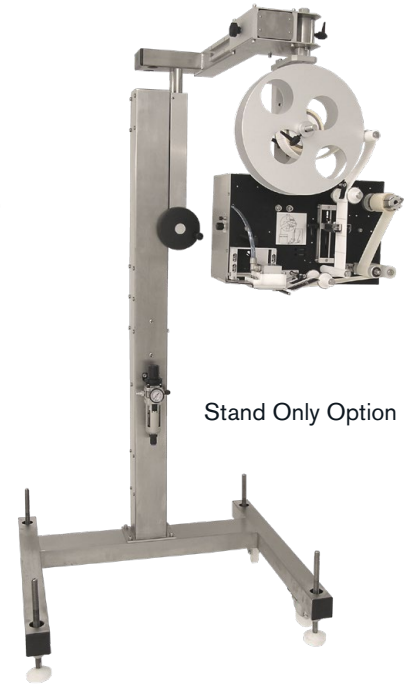

Stand Only Option

### 9 Finger Touch Applicator

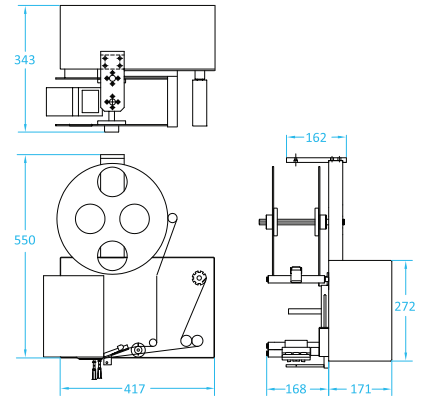
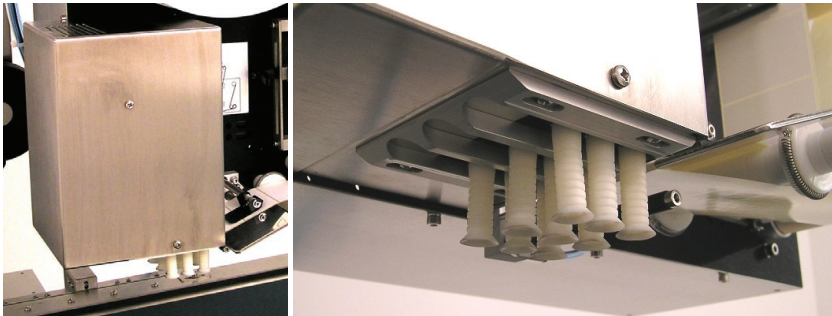

### Concave Shoe Applicator

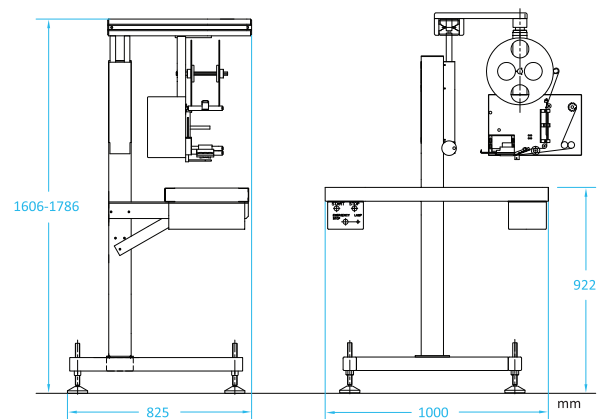
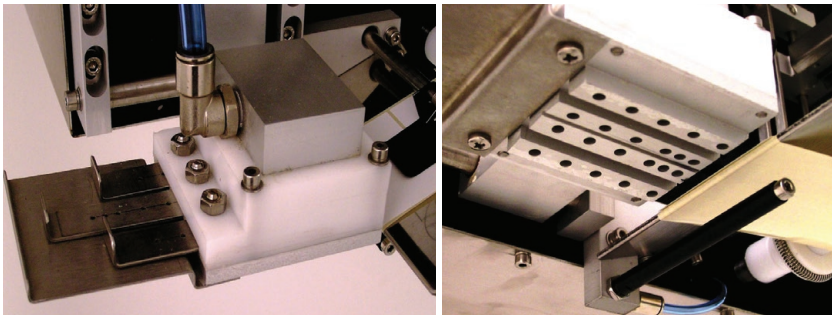

Specifications may change without notice

## LABELLING EQUIPMENT

LABELS | LABELLING EQUIPMENT | PACKAGING EQUIPMENT  
ESL & DIGITAL SIGNAGE | WEIGHING SCALES | POS SYSTEMS  
FOOD EQUIPMENT | MAINTENANCE & REPAIRS | HIRE

1300 970 111  
enquiries@wedderburn.com.au  
www.wedderburn.com.au